

## BioMaze® Fixed Film Media

In order to get the most out of your two year limited warranty, please register your product at <https://riovation.com/product-registration>

This limited warranty does not become effective until the end user completes and submits the warranty sheet found online.

Warranty information may be found at <https://riovation.com/limited-warranty>

### INSTALLATION MAINTENANCE & OPERATION MANUAL

## For BioMaze® Tri Series BMT

## Suspended Biofilm Generator® (SBG®) Models

---

BioMaze® Suspended Biofilm Generator® (SBG®) Tri Series BMT Model IMO Manual \* 2026-02-02

Page 1 of 10

[www.RioVation.com](http://www.RioVation.com)  
(352) 228-4488



PATENT NO: US 12,434,988 B2 AND  
OTHER PATENTS PENDING

## **INTRODUCTION**

This Operation and Maintenance (O&M) Manual has been prepared to provide essential guidance for the safe, effective, and reliable operation of BioMaze® High-Strength and Commercial Suspended Biofilm Generator® (SBG®) systems. These systems are engineered wastewater treatment solutions designed for applications with elevated organic loading, higher daily flows, variable influent characteristics, or enhanced performance requirements beyond conventional residential systems.

BioMaze® systems convert existing or new septic tanks and treatment vessels into high-efficiency, fixed-film aerobic treatment units by cultivating dense, attached-growth biofilm on specially designed suspended media. When supplied with continuous, controlled aeration—typically via FPZ regenerative blowers—the BioMaze® system establishes a robust aerobic biological environment capable of significantly reducing CBOD<sub>5</sub>, TSS, odors, and nutrients while producing effluent with high dissolved oxygen content.

High-Strength and Commercial BioMaze® installations are site-specific, engineered systems. Each system is designed based on project-specific parameters such as flow rate, influent strength, treatment objectives, tank geometry, blower capacity, and regulatory requirements. As a result, proper operation and routine maintenance are critical to achieving long-term treatment performance, protecting downstream components, and ensuring regulatory compliance.

This manual is intended for use by system owners, operators, certified maintenance entities, engineers, and qualified service professionals. It provides an overview of system components, operating principles, startup procedures, routine maintenance requirements, troubleshooting guidance, and recordkeeping expectations. It does not replace applicable permits, approved engineering documents, or local regulatory requirements, all of which take precedence where applicable.

Failure to operate or maintain the system in accordance with this manual may result in reduced treatment performance, equipment damage, or non-compliance with regulatory standards. Only qualified personnel should perform inspection, maintenance, or service activities on BioMaze® systems.

### **HOW the BioMaze® Suspended Biofilm Generator® (SBG®) Works**

As with any fixed-film media (FFM) treatment process, RioVation® BioMaze® High-Strength and Commercial systems provide a media surface for microorganisms to colonize, forming a biofilm. Wastewater is continuously mixed and circulated within the treatment chamber and across the BioMaze® media, allowing the microorganisms within the biofilm to metabolize organic matter, nutrients, and other waste constituents. This biological activity produces a treated effluent that is typically clear, low in odor, rich in dissolved oxygen, and aerobic bacteria.

The BioMaze® FFM is uniquely suited for high-strength and commercial applications due to its modular, scalable design. The system is composed of pod clusters, self-positioning BioMaze® Pods arranged in engineered clusters and quantities specific to the design flow, influent strength, and treatment objectives of each project. Pods are suspended within the treatment tank or vessel and installed through access risers or hatches without the need for internal structural modifications, allowing the system to be tailored to a wide range of tank sizes and configurations.

Each BioMaze® Pod is constructed from a proprietary plastic mesh media formed into a vertical cylindrical structure that allows wastewater to flow freely around and through the media. Fine-bubble ceramic diffusers, supplied by regenerative blowers, are integrated into designated aeration pods or pod clusters to provide uniform oxygen transfer and complete mixing throughout the treatment zone. This controlled aeration environment supports the development of a dense, highly active biofilm on the BioMaze® media surface.

As wastewater passes repeatedly through the aerated BioMaze® media, biofilm thickness increases in response to organic loading. Periodic sloughing of excess biomass occurs naturally and is an essential part of the treatment

BioMaze® Suspended Biofilm Generator® (SBG®) Tri Series BMT Model IMO Manual \* 2026-02-02

process. Due to the vertical orientation and open cylindrical geometry of the BioMaze® Pods, sloughed biomass is allowed to disengage from the media and settle to the bottom of the tank or basin as sludge, where it is retained until routine pumping or solids management is performed. This self-regulating process maintains optimal biofilm thickness and sustained treatment performance under variable and high-strength loading conditions.

The biofilm dynamically expands and contracts in response to changes in influent strength, hydraulic loading, and aeration rate, allowing BioMaze® high-strength and commercial systems to accommodate fluctuating operating conditions while maintaining consistent treatment efficiency.

## **ASSESSING THE SEPTIC TANK BEFORE INSTALLATION OF THE BIOMAZE® CONVERSION KIT**

Assess the septic tank(s) before installing the BioMaze® Suspended Biofilm Generator® (SBG®) Conversion Kit.

If the septic tank is not new, it may have been in the ground for a number of years and is likely covered with grass. Septic tanks can be one large tank, or a large tank separated into two compartments. It can also be multiple separate tanks in series. It is important to locate the entire tank(s) to accurately assess the septic tank before beginning the installation process. This can be easily done with a probe rod. Once you have located the outer edges of the tank(s), identify the outlet end of a single compartment final tank or the final compartment of a two-compartment tank. This is where the effluent discharges from and where the Pods will be installed. Measure the depth of the tank from the flow line to the bottom of the inside of the tank. A minimum of 34" is required to install the BioMaze® Pods. If there is not a riser with a minimum of 24" diameter already installed, a riser and lid are required to be installed on the septic tank lid. Depending on the system size and GPD flow more than one riser may be required. Follow the riser manufacturer's installation instructions and comply with state and county regulatory requirements.

Once you have located and removed all inspection ports and have pumped and cleaned all of the compartments of the septic tank in accordance with state and local requirements and have adequate riser(s) with lid(s) to the grade surface you are ready to start the BioMaze® Kit installation. *NOTE! When pumping, take appropriate precautions and refill the tanks immediately. Leaving the tank(s) empty could result in the tank(s) floating to the surface.*

## **INSTALLATION**

### **Instructions for the RioVation® BioMaze® Conversion Kit**

#### **1. BioMaze® Pod – Installation**

The BioMaze® High Strength/Commercial TRI Series Pods are made up of three separate 8" diameter x ~26" tall Pods attached into a Cluster with one or more fine air ceramic diffuser attached to each Cluster. These Clusters are easy to install. With the septic tank filled to operating level, lower the Pod Clusters into the septic tank through the riser access opening of the septic tank. The Pods will position themselves at the proper level.

#### **2. Air Pump & Housing with Integrated Alarm – Installation**

A. When considering where to locate the Air Pump & Housing with Integrated Alarm, it is recommended that it be located near an existing electrical power supply but no further than 100' from the septic tank. Electrical requirements will vary depending on blower size. Once you have decided on the location for the Air Pump Housing make sure the location is level. The Housing may be set directly on the ground with or without a pad.

B. Unpack items shipped in the Air Pump Housing as well as the blower from its box.

C. After connecting the air filter to the air pump, place the air pump in the air pump. Ensure the wires are connected to the beacon light to the top of the housing and the audible alarm on the side of the housing (these devices are not polarity sensitive). Make the air pump electrical connections. A disconnect (provided by others)

BioMaze® Suspended Biofilm Generator® (SBG®) Tri Series BMT Model IMO Manual \* 2026-02-02

Page 3 of 10

should be installed near the air pump housing. Run a 120 volt 20 amp dedicated circuit into the housing through the bottom corner of the housing under the electrical handy box mounted to the inside of the housing wall. Secure the wire into the bottom of the handy box and wire the provided 20 amp receptacle and install the provided cover. Plug into the handy box outlet the ventilation fan and the cord from the alarm control box. Plug the blower cord into the female cord from the alarm control box.

### 3. Connecting Air Line – Installation

A. With the blower situated inside the housing, connect and tighten the galvanized 2" union with the short piece of 2" schedule 40 PVC. The PVC should extend out of the housing through the hole that is predrilled. Connect the 1/8" diameter clear air line from the alarm control box to barb fitting that is mounted into the PVC which was just connected with the union.

B. A connecting airline must be installed between the air pump discharge to the 2" PVC line feeding air to the septic tank riser. Drill an appropriate size hole in the side of the septic tank riser (the riser which is being used to install the BioMaze® Pod Clusters) making sure it is above the wet season water table. Dig a shallow trench between the hole in the riser and the hole in the housing base.

C. Using proper PVC solvent weld cement and procedures, run the Sch 40 2" PVC pipe and any necessary fittings in the trench to the riser. Run the pipe to the outside edge of the riser. Install a Sch 40 2" PVC coupling and Sch 40 PVC 2" X 1 1/2" busing to the end of the PVC pipe at the riser. Run a short section of Sch 40 1 1/2" PVC through the riser and connect the eight (8) port manifold keeping it tight to the inside of the riser wall. Connect each Pod Cluster's 3/4" one of the 3/4" PVC hubs on the manifold. Seal the 2" Sch 40 PVC pipe to the riser using a state or county approved mastic or seal tight gasket that meets ASTM C 990.4.

### BioMaze® Suspended Biofilm Generator® (SBG®) Start-Up Instructions

A. Confirm all electrical connections are correct and tight. Turn on the electrical power. The alarm may momentarily sound before the air pressure comes up. Looking into the riser you should see good mixing or turbulence above and around the Pod Clusters.

B. Confirm there are no leaks in the piping between the air pump and riser. Backfill the shallow airline trench. Reinstall the required riser lid with security screws if required and any other required riser safety devices. Close the hinged Air Pump Housing and install the closure screw. *The septic tank is now converted into a BioMaze® Suspended Biofilm Generator® (SBG®).*

### HOW to Maintain the RioVation® BioMaze® Suspended Biofilm Generator® (SBG®)

The septic tank is now a Suspended Biofilm Generator® (SBG®) that actively treats the influent. By utilizing aerobic biofilm microorganisms (bacteria and other multi-cell organisms), the reactor reduces waste constituents in the wastewater typically producing clear, odorless effluent high in dissolved oxygen and aerobic bacteria which then passes to the drainfield which will usually extend the expected life of the drainfield. As with any biological or mechanical system, it is recommended that the Suspended Biofilm Generator® (SBG®) receive routine inspection and service. This should be done by an onsite wastewater professional. It is recommended to be performed every 6 (six) months with the following steps.

1. Open the tank riser lid(s).
2. Make a sample bottle using a clear cylinder about one pint in size. Attach the bottle to a 4' or longer handle using appropriate tape. (1/2" or 3/4" PVC pipe works well.)

3. Next catch an effluent sample for visual inspection from inside the treatment compartment, about six (6") inches under the liquid level. Upon inspection the effluent should have a non-offensive odor and be fairly clear in color.
4. There should be significant turbulence above the Aeration Diffusers caused by the rising air bubbles. Proper aeration in the Suspended Biofilm Generator® (SBG®) is maintained by the following maintenance operation.
  - A. Clean or replace the blower intake filter every six (6) months. Ensure electrical power is disconnected during this process. See blower manufacturers manual for instructions.
5. Always properly reinstall any related safety devices and lids and the access riser cover(s) with security screws if required. Reconnect blower to the power source. Close the blower Housing with Integrated Alarm and reinstall the closure screw.

### **Pumping and Cleaning the Septic Tank and BioMaze® Pods**

As with all septic tanks, the septic tank converted to a Suspended Biofilm Generator® (SBG®) will require periodic pumping and cleaning. This is usually necessary every 2 to 5 years but can vary with loading. Pumping should only be performed by a licensed septic tank pumper qualified to perform this task. To pump the tank, remove any necessary inspection port covers, whether risers to the surface or buried. Remove each BioMaze® Pod Cluster from the tank. As you remove each Cluster, hold them above the water line within the riser and spray them off with a garden hose to remove any and all sludge and foreign debris. Exercise caution to ensure all sludge and debris are rinsed into the tank. Use care so as not to damage the Pod Clusters. Pump all compartments. *NOTE! When pumping, take appropriate precautions and refill the tanks immediately. Leaving the tank(s) empty could result in the tank(s) floating to the surface.* Reinstall all the Pod Clusters according to the original installation instructions on page 3 of this manual. Make sure the Aeration Diffusers have good airflow. Always properly reinstall any related safety devices and lids and the access cover(s) of the tank riser along with security screws if required.

### **Diffuser Stone Replacement**

With the riser lid removed, remove each BioMaze® Pod Cluster from the tank via the access riser using the rope connected to each Cluster. As you remove each Cluster, hold them above the water line within the riser and spray them off with a garden hose to remove any and all sludge and foreign debris. Exercise caution to ensure all sludge and debris are rinsed into the tank. Use care so as not to damage the Clusters. Note where and how the diffuser assembly is attached to the Pod. You may want to take a picture for reference. Remove the zip ties from the diffuser and unscrew the diffuser from the 3/4" male pipe tread fitting clamped to the hose. (See diffuser pictures) With the diffuser in your hand remove the stainless-steel screw holding the assembly together. Disassemble and remove the stones and gaskets **taking note of the position of each component.** Reassemble in the reverse order using new gaskets and stones. Replace the stainless-steel screw holding the assembly together. Reassemble with new stones and gaskets making sure to align gaskets and diffuser stones properly so as to get a good airtight seal between each stone and the assembly. Tighten the completed assembly firmly by hand. Screw the diffuser assembly back on the 3/4" male pipe thread fitting clamped to the hose and tighten with wrenches using caution so as not to overtighten. Reattach the diffuser with the new zip ties provided in the kit making sure the diffuser is located in its original position on the Cluster. Reinstall the BioMaze® Clusters back into the tank according to the installation instructions on page 3 of this manual. Always properly reinstall any related safety devices and lids and the access cover(s) of the tank riser along with security screws if required. (The replacement stone and gasket kits are available on our website.)

**BioMaze® Porous Fine Air Diffuser Stone – ASSEMBLY**



RioVation®  
 BioMaze® Tri Series  
 Model BMT63HS

1. TANK DIMENSIONS SHOWN SCHEMATIC
2. EXACT PLACEMENT SUBJECT TO SITE CONDITIONS
3. DIMENSIONS INTENDED FOR INTERIM UNDERSTANDING AND
4. NOT TO BE USED FOR CONSTRUCTION
5. DIMENSIONS SHOWN UNLESS OTHERWISE NOTED
6. DIMENSIONS ARE MEAN DIMENSIONS
7. DIMENSIONS ARE MEAN DIMENSIONS
8. DIMENSIONS ARE MEAN DIMENSIONS

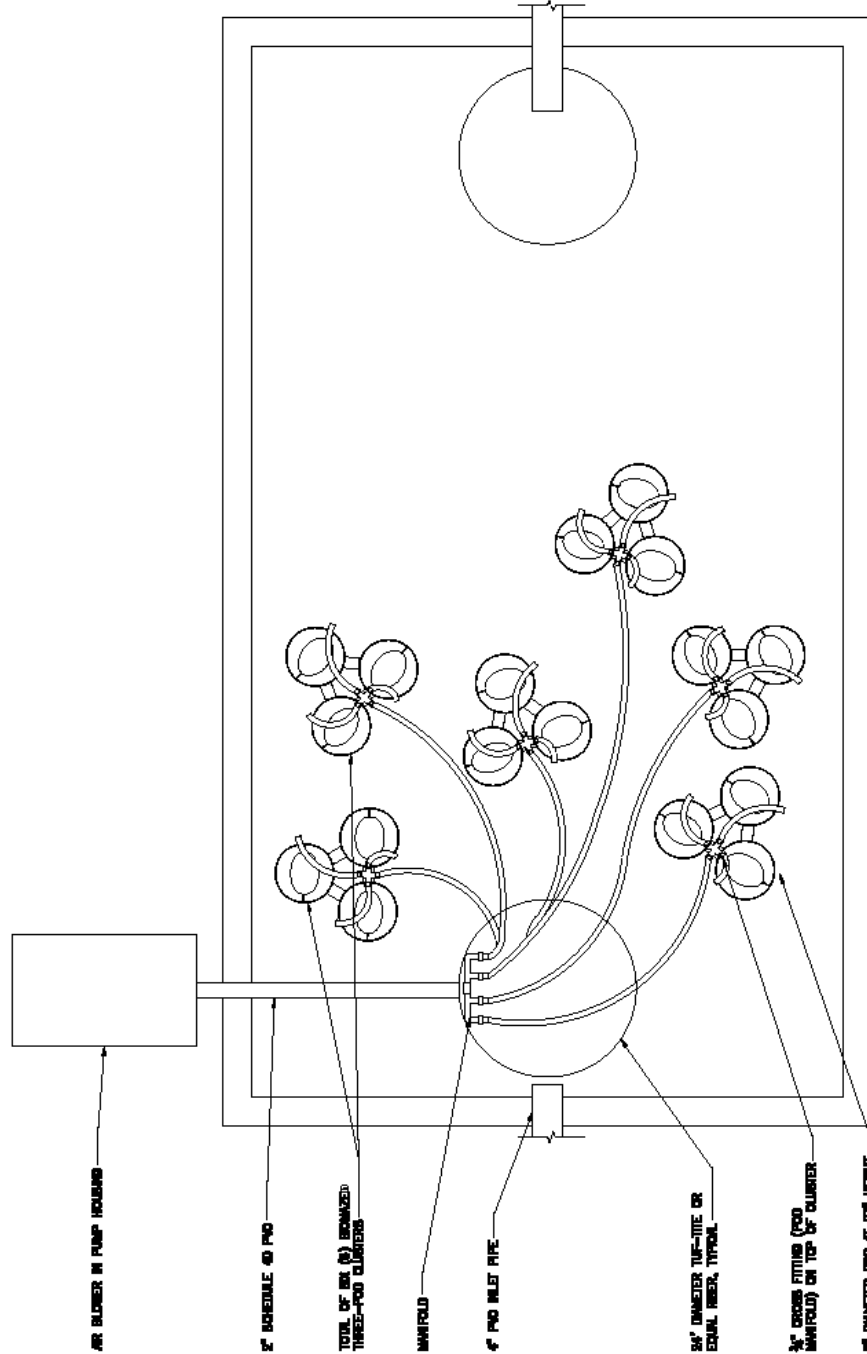

REAR VIEW - PLAN VIEW



JAN. 3, 2024  
 PATENT NOS. US 12,434,988 B2  
 AND OTHER PATENTS PENDING



RioVation®  
 BioMaze® Tri Series  
 Model BMT63HS

1. DRAW GEOMETRY FROM SCHEMATIC
2. EXACT PLACEMENT SUBJECT TO SITE CONDITIONS
3. DIMENSIONS INTENDED FOR BROWN UNDERGROUNDING AND CONDUITING
4. DIMENSIONS FROM MAIN UNLESS OTHERWISE NOTED
5. DIMENSIONS FROM MAIN UNLESS OTHERWISE NOTED
6. PIPES ARE SELF-POSITIONING AND NOT MECHANICALLY FIRED

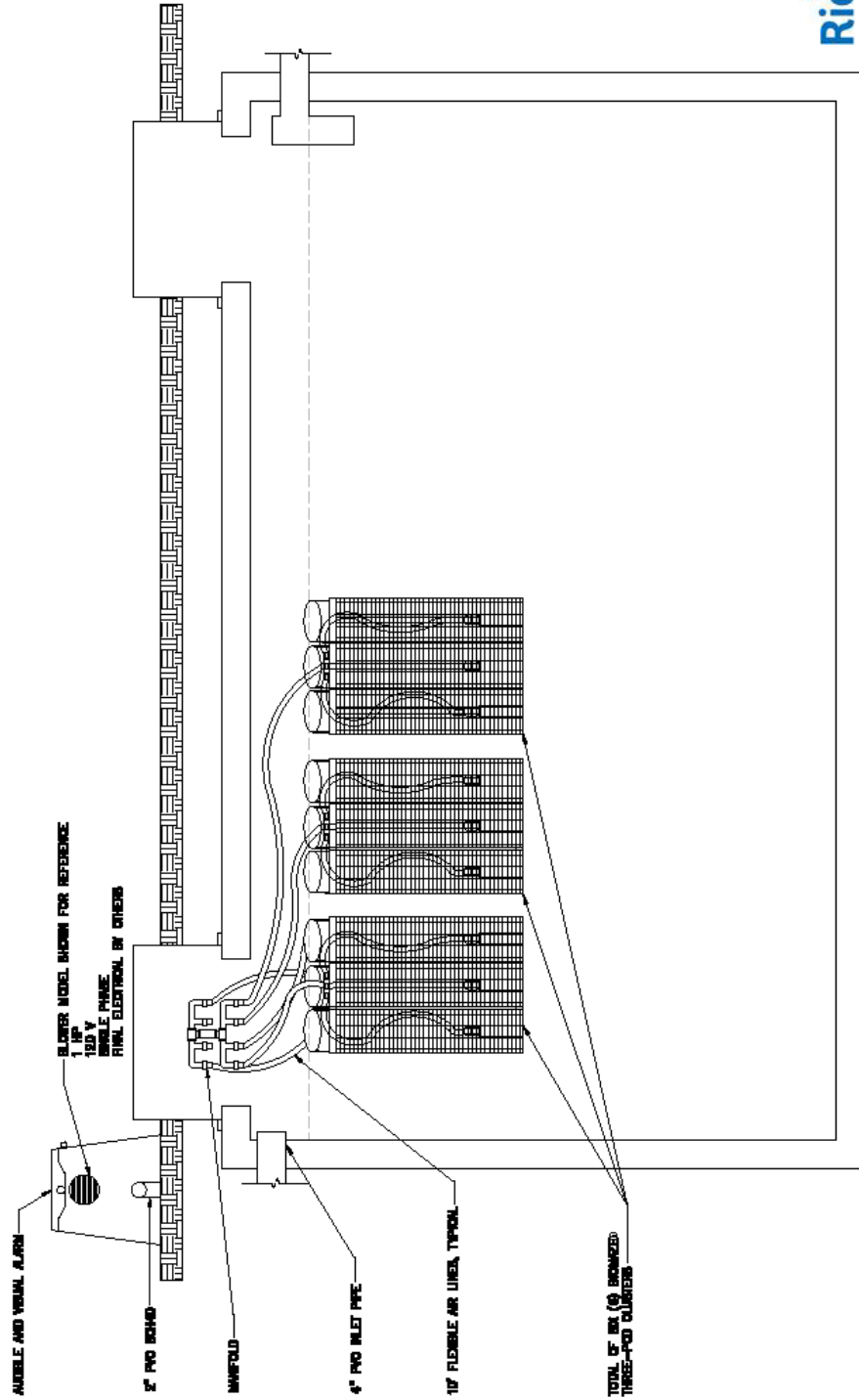

REVISED DRAWING - REVISED V03

BioMaze® Tri Series Pod Cluster

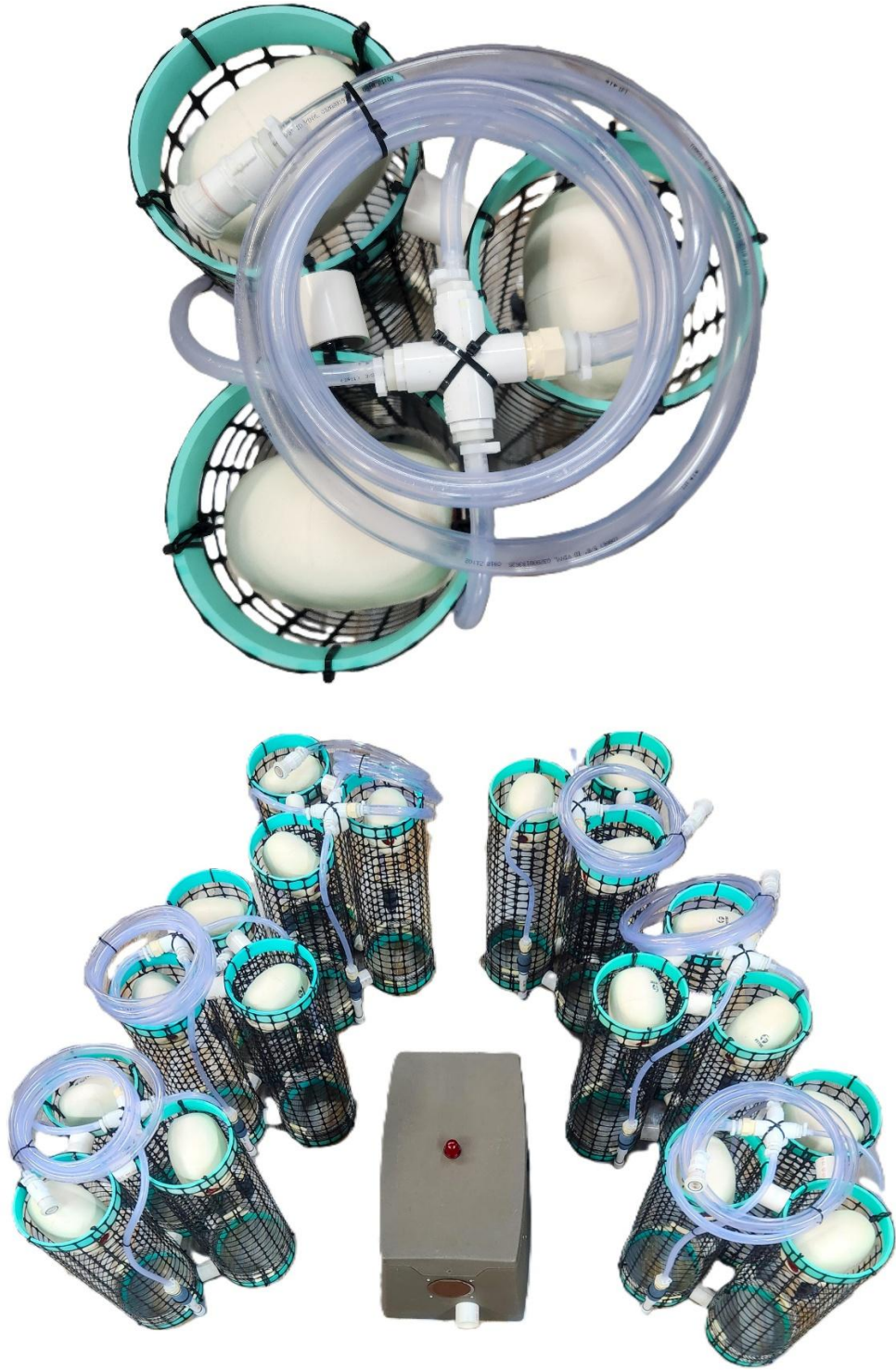

BioMaze® Suspended Biofilm Generator® (SBG®) Tri Series BMT Model IMO Manual \* 2026-02-02

Page 9 of 10

[www.RioVation.com](http://www.RioVation.com)  
(352) 228-4488



PATENT NO: US 12,434,988 B2 AND  
OTHER PATENTS PENDING

**BioMaze® Riser Air Delivery Manifold**



**BioMaze® 1HP Blower and Housing**





**SINGLE PHASE DUAL VOLTAGE**

**GENERAL SPECIFICATIONS:**

- 1. Type: AC Motor IEC 60034
- 2. Marks: cURus, CE
- 3. Poles: 2
- 4. Insulation class: F
- 5. Frequency: 60 hz
- 6. Enclosure: TEFC
- 7. Protection IP55, Tropicalized
- 8. Thermal protector: Klixon 140° C or 150° C (R series)
- 9. Max. Ambient 40° C
- 10. Duty: Continuous
- 11. Construction: aluminum frame

POWER		SIZE	VOLTAGE (60 hz)	Full Load Amperage	Starting Current A	Power Factor	SF	Capacitor μF	Cable Entry
HP	KW								
0.33	0.25	63	115 / 208-230	3.5 / 1.7	12.3 / 6.0	0.97	1.0	16 - 400 V	M16
0.5	0.37	63	115 / 208-230	4.8 / 2.6	16.8 / 9.1	0.96	1.0	16 - 400 V	M16
0.75	0.55	71	115 / 208-230	9.8 / 4.9	46.1 / 23.0	0.95	1.0	20 - 400 V	M16
0.75	0.55	71	115 / 208-230	8.3 / 4.1-4.2	34.9 / 17.2	0.83	1.15	30 - 450 V	M20
1	0.75	80	115 / 208-230	13.0 / 7.2	49.4 / 24.7	0.77	1.0	31.5 - 400 V	M20
1	0.75	80	115 / 208-230	9.4 / 5.5-5.0	35.8 / 17.3	0.99	1.15	40 - 450 V	M20
1.5	1.1	80	115 / 208-230	13.6 / 7.3	54.4 / 29.2	0.97	1.0	50 - 400 V	M20
1.5	1.1	80	115 / 208-230	14.6 / 7.6-7.3	49.3 / 23.2	0.97	1.15	45 - 450 V	M20
1.5*	1.1	80	115 / 208-230	14.3 / 7.18	71.1 / 35	0.96	1.0	55 - 450 V	M20
2	1.5	90	115 / 208-230	24.0 / 12.0	79.2 / 39.6	0.90	1.0	70 - 400 V	M20
2	1.5	90	115 / 208-230	19.7 / 10.6-9.9	103 / 52.4	0.95	1.15	50 - 450 V	M20
2*	1.5	80	115 / 208-230	19.4 / 9.8	96 / 48.2	0.89	1.0	55 - 450 V	M20
3	2.2	90	115 / 208-230	31.5 / 16.0	154.4 / 78.4	0.85	1.0	60 - 400 V	M20
3	2.2	90	115 / 208-230	29.4 / 16.6-14.8	119.8 / 61.8	0.91	1.15	45 - 450 V	M20
3*	2.2	90	115 / 208-230	26.2 / 13.1	152 / 76	0.95	1.0	70 - 450 V	M20

\* Applicable to R series ONLY.

Shaded models to be discontinued.

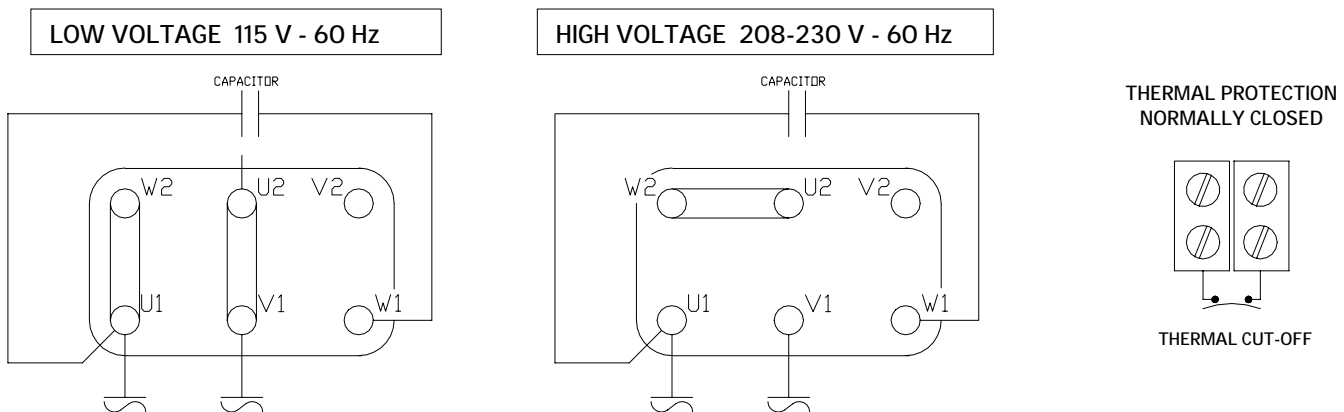

Specifications subject to change without notice. Alternate motor suppliers may be used.